

6.2 精密研磨級滾珠螺桿尺寸

F S V TYPE

◀ 規格品

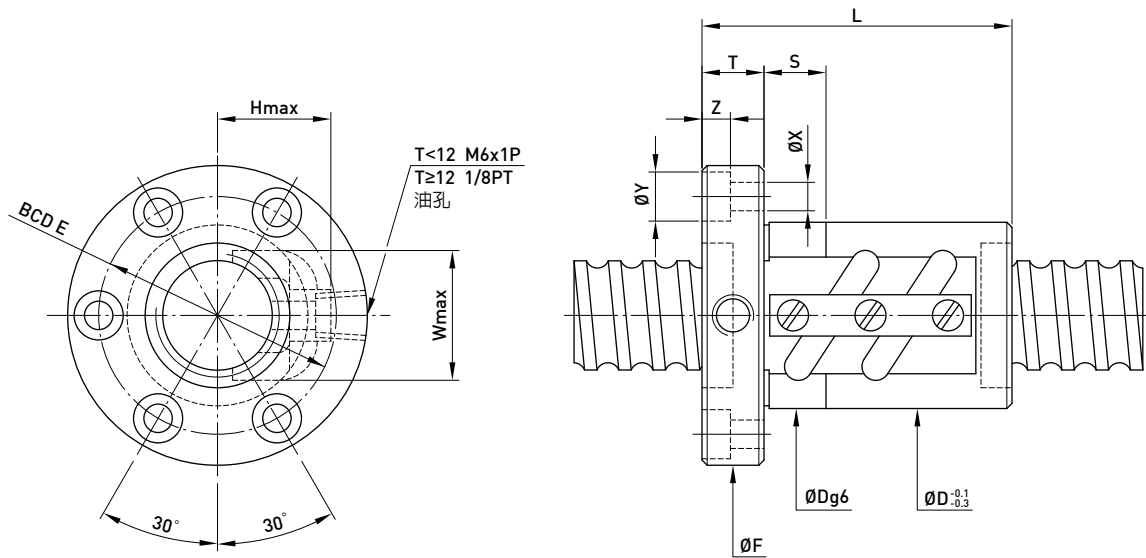

型號	規格		珠徑	PCD	根徑	珠卷數	剛性 Kgf/μm K	動負荷 C [kgf]	靜負荷 Co [kgf]	螺帽		法蘭			迴流管		法蘭孔			接觸 面長
	公稱 外徑	導程								D	L	F	T	BCD-E	W	H	X	Y	Z	
16-4B2	16	4	2.381	16.25	13.792	2.5x2	26	802	1722	30	48	52	10	40	23	21	5.5	9.5	5.5	12
16-5B1		5	3.175	16.6	13.324	2.5x1	16	763	1400	31	45	54	12	41	27	22	5.5	9.5	5.5	12
16-5B2		5		16.6	13.324	2.5x2	33	1385	2799	31	60	54	12	41	27	22	5.5	9.5	5.5	12
16-5C1		5		16.6	13.324	3.5x1	22	1013	1946	31	50	54	12	41	27	22	5.5	9.5	5.5	12
16-10B1	10	10	3.175	16.6	13.324	2.5x1	16	763	1399	30	54	53	10	41	22.5	23	5.5	9.5	5.5	12
20-5B1	20	5	3.969	20.6	17.324	2.5x1	19	837	1733	35	45	58	12	46	27	25	5.5	9.5	5.5	12
20-5B2		5		20.6	17.324	2.5x2	39	1519	3465	35	60	58	12	46	27	25	5.5	9.5	5.5	12
20-6B1		6	20.8	16.744	2.5x1	20	1139	2187	36	48	60	12	47	28	27	5.5	9.5	5.5	12	
20-6C1		6	20.8	16.744	3.5x1	28	1512	3041	36	66	60	12	47	28	27	5.5	9.5	5.5	12	
20-20A1	20	20	1.5x1	20.8	16.744	1.5x1	13	719	1281	36	66	60	12	47	28	27	5.5	9.5	5.5	12
25-5B2	25	5	3.175	25.6	22.324	2.5x2	46	1704	4417	40	60	64	12	52	31	26	5.5	9.5	5.5	12
25-5C1		5	25.6	22.324	3.5x1	35	1252	3085	40	50	64	12	52	31	26	5.5	9.5	5.5	12	
25-6B2		6	3.969	25.8	21.744	2.5x2	48	2308	5523	42	68	68	12	55	32	28	6.6	11	6.5	12
25-6C1		6	25.8	21.744	3.5x1	35	1690	3844	42	55	68	12	55	32	28	6.6	11	6.5	12	
25-8B2	25	8	4.763	26	21.132	2.5x2	46	2888	6472	50	80	74	13	62	35	31	5.5	9.5	5.5	15
25-10B1		10		26	21.132	2.5x1	25	1592	3237	45	65	72	16	58	34	29	6.6	11	6.5	12
25-10B2		10	26	21.132	2.5x2	46	2888	6472	47	97	74	15	60	35	31	6.6	11	6.5	15	
25-16B1		16	26	21.132	2.5x1	28	1592	3237	45	84	72	16	58	34	29	6.6	11	6.5	12	
25-20B1	20	26	21.132	2.5x1	28	1592	3237	45	96	72	16	58	34	29	6.6	11	6.5	12		
25-25A1	25	26	21.132	1.5x1	16	1019	1927	45	90	72	16	58	34	29	6.6	11	6.5	12		
28-5B1	28	5	3.175	28.6	25.324	2.5x1	26	984	2466	44	45	70	12	56	34	28	6.6	11	6.5	12
28-5B2		5		28.6	25.324	2.5x2	50	1785	4932	44	60	70	12	56	34	28	6.6	11	6.5	12
28-6A2		6	28.6	25.324	1.5x2	29	1150	2960	44	55	70	12	56	34	28	6.6	11	6.5	12	
28-6B2		6	28.6	25.324	2.5x2	48	1784	4932	50	61	74	12	60	36	29	6.6	11	6.5	15	
32-5B2	32	5	3.969	32.6	29.324	2.5x2	55	1886	5666	50	60	76	12	63	38	30	6.6	11	6.5	12
32-5C1		5		32.6	29.324	3.5x1	39	1388	3967	50	50	76	12	63	38	30	6.6	11	6.5	12
32-6B2		6	32.8	28.744	2.5x2	56	2556	7020	52	68	78	12	65	39	32	6.6	11	6.5	12	
32-6C1		6	32.8	28.744	3.5x1	39	1888	4936	52	55	78	12	65	39	32	6.6	11	6.5	12	
32-8B2	32	8	4.763	33	28.132	2.5x2	59	3284	8453	54	86	88	16	70	40	33	9	14	8.5	15
32-8C1		8		33	28.132	3.5x1	41	2428	5948	54	70	88	16	70	40	33	9	14	8.5	15
32-10B1		10	33.4	26.91	2.5x1	30	2650	5599	54	70	88	16	70	44	37	9	14	8.5	15	
32-10B2		10	33.4	26.91	2.5x2	60	4810	11199	57	98	91	16	73	44	37	9	14	8.5	15	
32-10C1	10	33.4	26.91	3.5x1	44	3519	7785	57	78	91	16	73	44	37	9	14	8.5	15		
32-16B1	16	33.4	26.91	2.5x1	30	2650	5599	54	100	88	16	70	45	38	9	14	8.5	15		
32-20B1	20	33	28.132	2.5x1	33	1810	4227	54	100	88	16	70	40	33	9	14	8.5	15		
32-25B1	25	33	28.132	2.5x1	33	1810	4227	54	118	88	16	70	40	33	9	14	8.5	15		
32-32A1	32	33	28.132	1.5x1	18	1154	2505	54	110	88	16	70	40	33	9	14	8.5	15		
36-6B1	36	6	3.969	36.8	32.744	2.5x1	35	1486	3969	55	50	82	12	68	42	32	6.6	11	6.5	12
36-6B2		6	36.8	32.744	2.5x2	60	2696	7937	55	68	82	12	68	42	32	6.6	11	6.5	12	

註：表列剛性值，在無預壓力時軸向負荷為30%動負荷的條件下計算之。

F S V TYPE

◀ 規格品

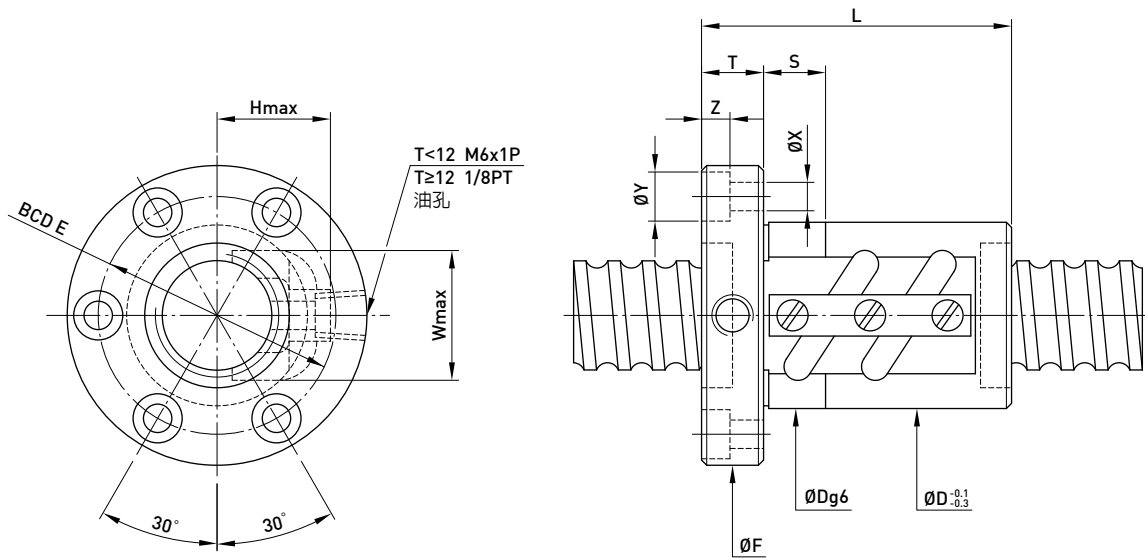

型號	規格		珠徑	PCD	根徑	珠卷數	剛性 Kgf/μm K	動負荷 C [kgf]	靜負荷 Co [kgf]	螺帽		法蘭			迴流管		法蘭孔			接觸 面長
	公稱 外徑	導程								D	L	F	T	BCD-E	W	H	X	Y	Z	
36-10B2	36	10	6.350	37.4	30.91	2.5x2	68	5105	12669	62	102	104	18	82	49	40	11	17.5	11	15
40-5B2	40	5	3.175	40.6	37.324	2.5x2	66	2071	7134	58	65	92	16	72	46	34	9	14	8.5	15
40-6B2		6	3.969	40.8	36.744	2.5x2	69	2817	8855	60	72	94	16	76	47	36	9	14	8.5	15
40-8B2		8	4.763	41	36.132	2.5x2	70	3634	10603	62	86	96	16	78	48	38	9	14	8.5	15
40-8C1				41	36.132	3.5x1	49	2679	7438	62	70	96	16	78	48	38	9	14	8.5	15
40-10B2		10	6.350	41.4	34.91	2.5x2	74	5370	14138	65	102	106	18	85	52	42	11	17.5	11	15
40-10C1				41.4	34.91	3.5x1	51	3932	9841	65	82	106	18	85	52	42	11	17.5	11	15
40-12B2		12	7.144	41.6	34.299	2.5x2	72	6216	15674	64	108	112	18	88	53	42	11	17.5	11	30
40-16B2		16		41.6	34.299	2.5x2	72	6216	15674	74	135	110	18	90	52	49	11	17.5	11	30
40-25B1		25	45	41.4	34.91	2.5x1	39	2959	7069	65	123	106	18	85	52	42	11	17.5	11	15
40-32B1		32		41.4	34.91	2.5x1	39	2959	7069	65	146	106	18	85	52	42	11	17.5	11	15
40-40A1	40	6.350		41.4	34.91	1.5x1	24	1875	4159	65	133	106	18	85	52	42	11	17.5	11	15
45-10B1	10	46.4		39.91	2.5x1	45	4170	11161	70	74	112	18	90	58	48	11	17.5	11	15	
45-10B2	12	7.938	46.4	39.91	2.5x2	79	5655	15905	70	104	112	18	90	58	48	11	17.5	11	15	
45-12B2			46.8	38.688	2.5x2	81	7627	19799	74	123	122	22	97	60	49	13	20	13	20	
50-5A2	50	5	50.6	47.324	1.5x2	48	1447	5382	70	63	104	16	86	56	40	9	14	8.5	15	
50-5A3			50.6	47.324	1.5x3	73	2051	8072	70	73	104	16	86	56	40	9	14	8.5	15	
50-6B2		6	3.969	50.8	46.744	2.5x2	81	3093	11149	72	75	106	16	88	57	43	9	14	8.5	15
50-6B3				50.8	46.744	2.5x3	119	4384	16723	72	93	106	16	88	57	43	9	14	8.5	15
50-8B2		8	4.763	51	46.132	2.5x2	84	4004	13409	75	88	116	18	95	58	45	11	17.5	11	15
50-8B3				51	46.132	2.5x3	124	5674	20114	75	112	116	18	95	58	45	11	17.5	11	15
50-10B2		10	6.350	51.4	44.91	2.5x2	87	5923	17670	78	104	119	18	98	62	48	11	17.5	11	15
50-10B3				51.4	44.91	2.5x3	129	8394	26505	78	134	119	18	98	62	48	11	17.5	11	15
50-10C1				51.4	44.91	3.5x1	60	4393	12481	78	84	119	18	98	62	48	11	17.5	11	15
50-12B1				12	7.938	51.8	43.688	2.5x1	46	4420	11047	82	87	130	22	105	64	52	13	20
50-12B2	51.8	43.688	2.5x2			90	8022	22094	82	123	130	22	105	64	52	13	20	13	20	
50-12C1	51.8	43.688	3.5x1	63	5875	15380	82	99	130	22	105	64	52	13	20	13	20			
50-40A1	40	51.8	43.688	1.5x1	27	2801	6499	82	135	130	22	105	64	52	13	20	13	20		
50-50A1	50	51.8	43.688	1.5x1	30	2801	6499	82	162	130	22	105	64	52	13	20	13	20		
55-10C1	55	10	6.350	56.4	49.91	3.5x1	66	4562	13661	84	84	125	18	103	68	54	11	17.5	11	20
55-12B2		12	7.938	56.8	48.688	2.5x2	95	8392	24390	88	123	136	22	110	70	56	13	20	13	20
55-20B2		20	12.700	58	45.16	2.5x2	127	20160	52439	100	175	132	28	115	74	71	9	14	8.5	30
63-8A2	63	8	4.763	64	59.132	1.5x2	54	2826	10129	87	76	129	18	107	70	50	11	17.5	11	20
63-8A3				64	59.132	1.5x3	80	4004	15193	87	92	129	18	107	70	50	11	17.5	11	20
63-10B2		10	6.350	64.4	57.91	2.5x2	104	6533	22371	90	107	132	20	110	74	53	11	17.5	11	20
63-10B3				64.4	57.91	2.5x3	154	9258	33556	90	137	132	20	110	74	53	11	17.5	11	20
63-12B2		12	7.938	64.8	56.688	2.5x2	109	8943	28062	94	124	142	22	117	76	57	13	20	13	20
63-16B2		16	9.525	65.2	55.466	2.5x2	141	14862	46009	100	153	150	22	123	78	62	13	20	13	20
63-20B2	20	12.700	65.2	55.466	2.5x2	141	14862	46009	100	176	150	22	123	78	62	13	20	13	20	

註：表列剛性值，在無預壓力時軸向負荷為30%動負荷的條件下計算之。

F S V TYPE

◀ 規格品

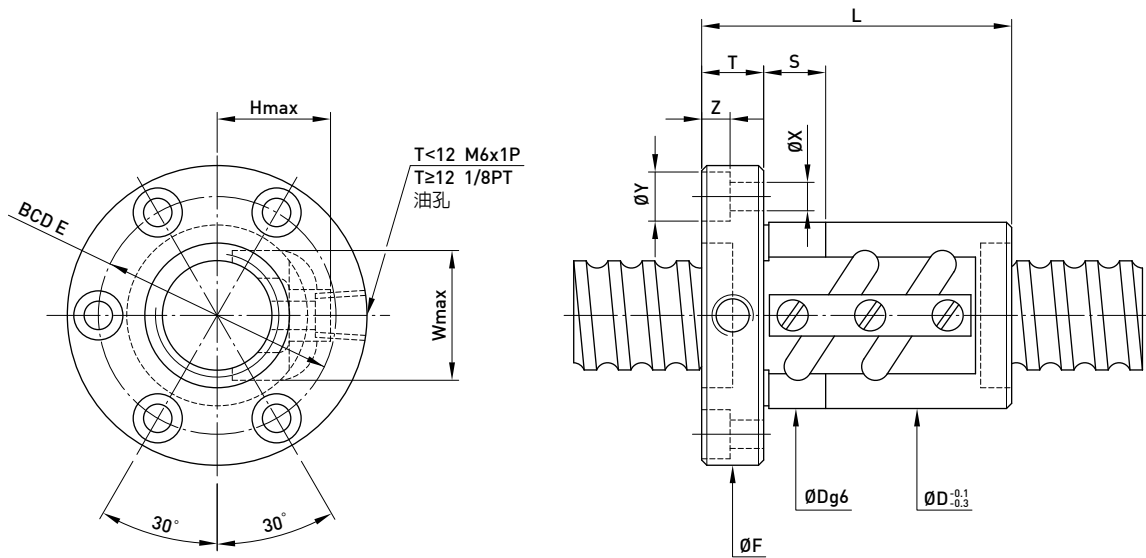

型號	規格		珠徑	PCD	根徑	珠卷數	剛性 Kgf/μm K	動負荷 C [kgf]	靜負荷 Co [kgf]	螺帽		法蘭			迴流管		法蘭孔			接觸 面長	
	公稱 外徑	導程								D	L	F	T	BCD-E	W	H	X	Y	Z		S
63-20B3	63	20	12.700	66	53.16	2.5x3	210	30715	90887	117	244	157	32	137	82	70	11	17.5	11	30	
70-10B2	70	10	6.350	71.4	64.91	2.5x2	115	6843	25011	104	109	152	20	128	80	56	13	20	13	20	
70-10B3		10	6.350	71.4	64.91	2.5x3	170	9688	37516	104	139	152	20	128	80	56	13	20	13	20	
70-12B2		12	7.938	71.8	63.688	2.5x2	120	9382	31275	110	125	159	22	133	82	58	13	20	13	20	
70-12B3		12	7.938	71.8	63.688	2.5x3	170	13296	46912	110	159	159	22	133	82	58	13	20	13	20	
80-10B2	80	10	6.350	81.4	74.91	2.5x2	126	7202	28538	115	109	163	22	137	90	64	13	20	13	20	
80-10B3		10	6.350	81.4	74.91	2.5x3	186	10207	42807	115	139	163	22	137	90	64	13	20	13	20	
80-12B2		12	7.938	81.8	73.688	2.5x2	130	9797	35422	120	125	169	22	143	92	67	13	20	13	25	
80-12B3		12	7.938	81.8	73.688	2.5x3	192	13884	53132	120	159	169	22	143	92	67	13	20	13	25	
80-16B2		16	9.525	82.2	72.466	2.5x2	171	16485	58851	125	156	190	28	154	94	70	18	26	17.5	25	
80-16B3			9.525	82.2	72.466	2.5x3	252	23363	88276	125	204	190	28	154	94	70	18	26	17.5	25	
80-20B2			20	9.525	82.2	72.466	2.5x2	171	16485	58851	125	185	190	28	154	94	70	18	26	17.5	25
80-20B3				9.525	82.2	72.466	2.5x3	252	23363	88276	125	245	190	28	154	94	70	18	26	17.5	25
100-12B2		100	12	7.938	101.8	93.688	2.5x2	156	10761	44586	145	132	209	28	173	112	76	18	26	17.5	25
100-12B3			12	7.938	101.8	93.688	2.5x3	229	15251	66894	145	168	209	28	173	112	76	18	26	17.5	25
100-16B2	16		9.525	102.2	92.466	2.5x2	200	18123	74425	150	162	228	32	185	114	80	22	32	21.5	30	
100-16B3			9.525	102.2	92.466	2.5x3	305	25684	111637	150	212	228	32	185	114	80	22	32	21.5	30	
100-20B2			20	9.525	102.2	92.466	2.5x2	200	18123	74425	150	190	228	32	185	114	80	22	32	21.5	30
100-20B3				9.525	102.2	92.466	2.5x3	305	25684	111637	150	250	228	32	185	114	80	22	32	21.5	30

註：表列剛性值，在無預壓力時軸向負荷為30%動負荷的條件下計算之。