

AF系列 (方形支撐側)

Support Unit AF
(Supported-side rectangular type)

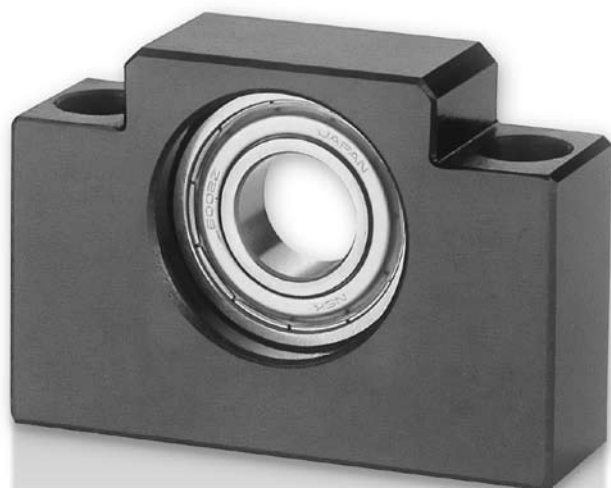

編號/Part No.	部品名稱/Part name	數量/Qty
1	軸承座本體/Housing	1
2	軸承/Bearing	1組/1 set
3	C型扣環/Snap ring	1

AF

2-ØX鑽穿ØY鑽深Z
2-X drill ØY counter bore depth Z

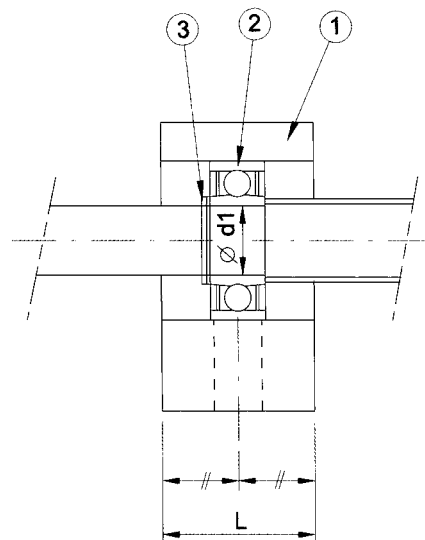
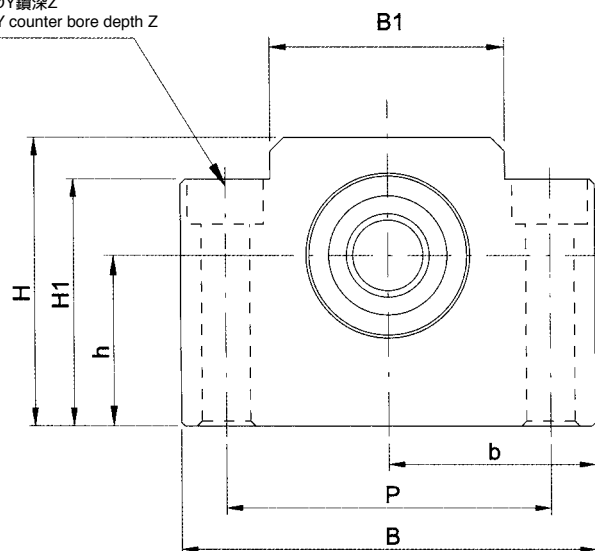

單位 / Unit : mm

型號 Model No.	軸徑 Shaft diameter d1	L	B	H	b	h	B1	H1	P	X	Y	Z	E	使用軸承 Bearing	使用C型扣環 Snap ring
					±0.02	±0.02									
AF10	8	20	70	43	35	25	36	35	52	9	14	11	15	608ZZ	S 8
AF12	10	20	70	43	35	25	36	35	52	9	14	11	15	6000ZZ	S 10
AF15	15	20	80	50	40	30	41	40	60	9	14	11	15	6002ZZ	S 15
AF20	20	26	95	58	47.5	30	56	45	75	11	17	15	15	6204ZZ	S 20

接受表面特殊處理之訂製 Surface Special treatment is available.