

(2) HGL-CA / HGL-HA

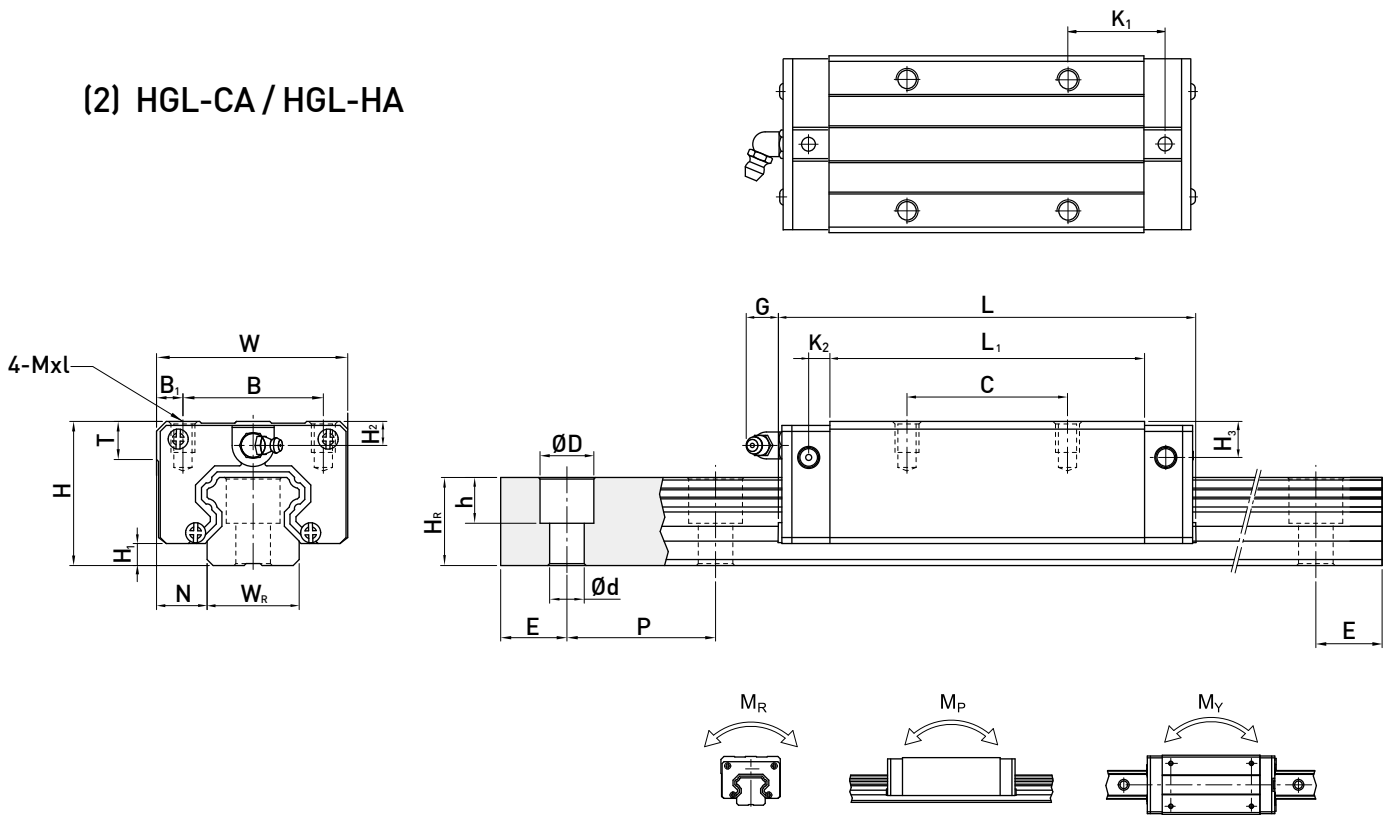

型號	組件尺寸 (mm)		滑塊尺寸 (mm)										滑軌尺寸 (mm)					滑軌的 固定螺 栓尺寸 (mm)	基本 動額 定負荷 C(kN)	基本 靜額 定負荷 C <sub>0</sub> (kN)	容許靜力矩			重量							
	H	H <sub>1</sub>	N	W	B	B <sub>1</sub>	C	L <sub>1</sub>	L	K <sub>1</sub>	K <sub>2</sub>	G	Mxl	T	H <sub>2</sub>	H <sub>3</sub>	W <sub>R</sub>				H <sub>R</sub>	D	h	d	P	E	M <sub>R</sub>	M <sub>P</sub>	M <sub>Y</sub>	滑塊	滑軌
	mm	mm	mm	mm	mm	mm	mm	mm	mm	mm	mm	mm	mm	mm	mm	mm	mm				mm	mm	mm	mm	mm	mm	kN-m	kN-m	kN-m	kg	kg/m
HGL 15CA	24	4.3	9.5	34	26	4	26	39.4	61.4	10	4.85	5.3	M4x4	6	3.95	3.7	15	15	7.5	5.3	4.5	60	20	M4x16	11.38	16.97	0.12	0.10	0.10	0.14	1.45
HGL 25CA	36	5.5	12.5	48	35	6.5	35	58	84	15.7	6	12	M6x6	8	6	5	23	22	11	9	7	60	20	M6x20	26.48	36.49	0.42	0.33	0.33	0.42	3.21
HGL 25HA							50	78.6	104.6	18.5															32.75	49.44	0.56	0.57	0.57	0.57	
HGL 30CA	42	6	16	60	40	10	40	70	97.4	20.25	6	12	M8x10	8.5	6.5	10.8	28	26	14	12	9	80	20	M8x25	38.74	52.19	0.66	0.53	0.53	0.78	4.47
HGL 30HA							60	93	120.4	21.75															47.27	69.16	0.88	0.92	0.92	1.03	
HGL 35CA	48	7.5	18	70	50	10	50	80	112.4	20.6	7	12	M8x12	10.2	9	12.6	34	29	14	12	9	80	20	M8x25	49.52	69.16	1.16	0.81	0.81	1.14	6.30
HGL 35HA							72	105.8	138.2	22.5															60.21	91.63	1.54	1.40	1.40	1.52	
HGL 45CA	60	9.5	20.5	86	60	13	60	97	139.4	23	10	12.9	M10x17	16	8.5	20.5	45	38	20	17	14	105	22.5	M12x35	77.57	102.71	1.98	1.55	1.55	2.08	10.41
HGL 45HA							80	128.8	171.2	28.9															94.54	136.46	2.63	2.68	2.68	2.75	
HGL 55CA	70	13	23.5	100	75	12.5	75	117.7	166.7	27.35	11	12.9	M12x18	17.5	12	19	53	44	23	20	16	120	30	M14x45	114.44	148.33	3.69	2.64	2.64	3.25	15.08
HGL 55HA							95	155.8	204.8	36.4															139.35	196.20	4.88	4.57	4.57	4.27	

註 : 1 kgf = 9.81 N