

線性滑軌

HG系列

(5) HGW-CC / HGW-HC

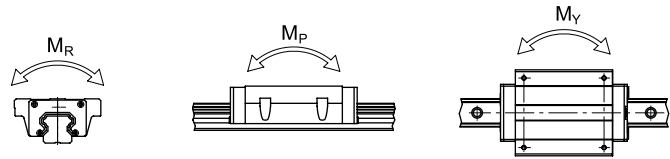
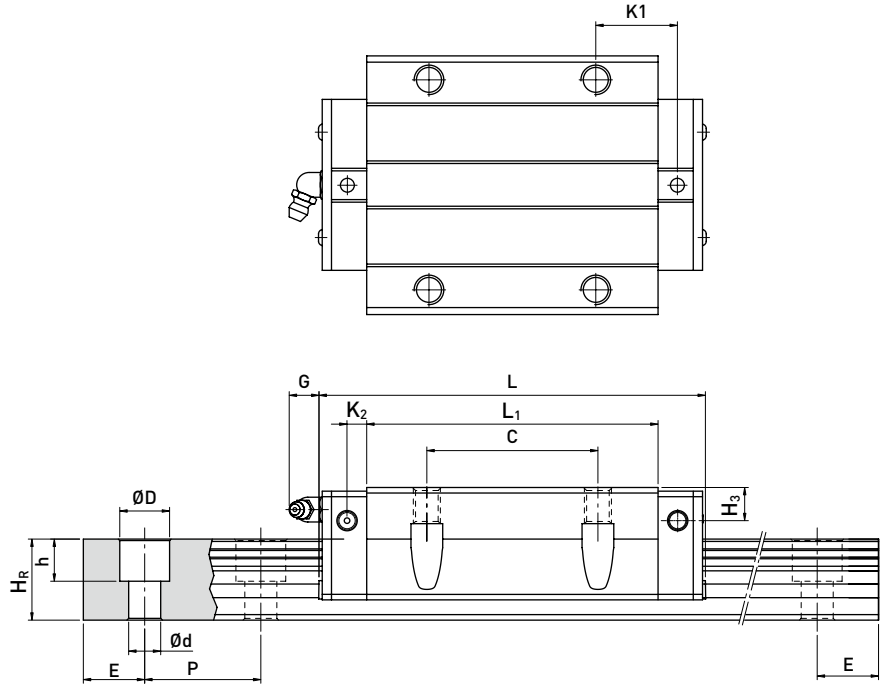
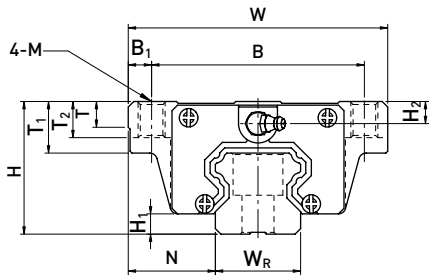

型號	組件尺寸 (mm)			滑塊尺寸 (mm)													滑軌尺寸 (mm)					滑軌的固定螺柱尺寸 (mm)	基本動額定負荷 C(kN)	基本靜額定負荷 C ₀ (kN)	容許靜力矩			重量					
	H	H ₁	N	W	B	B ₁	C	L ₁	L	K ₁	K ₂	G	M	T	T ₁	T ₂	H ₂	H ₃	W _R	H _R	D				h	d	P	E	M _R	M _P	M _Y	滑塊	滑軌
	mm	mm	mm	mm	mm	mm	mm	mm	mm	mm	mm	mm	mm	mm	mm	mm	mm	mm	mm	mm	mm				mm	mm	mm	mm	kN-m	kN-m	kN-m	kg	kg/m
HGW 15CC	24	4.3	16	47	38	4.5	30	39.4	61.4	8	4.85	5.3	M5	6	8.9	6.95	3.95	3.7	15	15	7.5	5.3	4.5	60	20	M4x16	11.38	16.97	0.12	0.10	0.10	0.17	1.45
HGW 20CC	30	4.6	21.5	63	53	5	40	50.5	77.5	10.25	6	12	M6	8	10	9.5	6	6	20	17.5	9.5	8.5	6	60	20	M5x16	17.75	27.76	0.27	0.20	0.20	0.40	2.21
HGW 20HC								65.2	92.2	17.6																	21.18	35.90	0.35	0.35	0.35	0.52	
HGW 25CC	36	5.5	23.5	70	57	6.5	45	58	84	10.7	6	12	M8	8	14	10	6	5	23	22	11	9	7	60	20	M6x20	26.48	36.49	0.42	0.33	0.33	0.59	3.21
HGW 25HC								78.6	104.6	21																	32.75	49.44	0.56	0.57	0.57	0.80	
HGW 30CC	42	6	31	90	72	9	52	70	97.4	14.25	6	12	M10	8.5	16	10	6.5	10.8	28	26	14	12	9	80	20	M8x25	38.74	52.19	0.66	0.53	0.53	1.09	4.47
HGW 30HC								93	120.4	25.75																	47.27	69.16	0.88	0.92	0.92	1.44	
HGW 35CC	48	7.5	33	100	82	9	62	80	112.4	14.6	7	12	M10	10.1	18	13	9	12.6	34	29	14	12	9	80	20	M8x25	49.52	69.16	1.16	0.81	0.81	1.56	6.30
HGW 35HC								105.8	138.2	27.5																	60.21	91.63	1.54	1.40	1.40	2.06	
HGW 45CC	60	9.5	37.5	120	100	10	80	97	139.4	13	10	12.9	M12	15.1	22	15	8.5	20.5	45	38	20	17	14	105	22.5	M12x35	77.57	102.71	1.98	1.55	1.55	2.79	10.41
HGW 45HC								128.8	171.2	28.9																	94.54	136.46	2.63	2.68	2.68	3.69	
HGW 55CC	70	13	43.5	140	116	12	95	117.7	166.7	17.35	11	12.9	M14	17.5	26.5	17	12	19	53	44	23	20	16	120	30	M14x45	114.44	148.33	3.69	2.64	2.64	4.52	15.08
HGW 55HC								155.8	204.8	36.4																	139.35	196.20	4.88	4.57	4.57	5.96	
HGW 65CC	90	15	53.5	170	142	14	110	144.2	200.2	23.1	14	12.9	M16	25	37.5	23	15	15	63	53	26	22	18	150	35	M16x50	163.63	215.33	6.65	4.27	4.27	9.17	21.18
HGW 65HC								203.6	259.6	52.8																	208.36	303.13	9.38	7.38	7.38	12.89	

註：1 kgf = 9.81 N