

# SGH-C 鋼片型 / 夾緊式 / 短型撓性聯軸器

DISK / CLAMP TYPE / SHORTER OF FLEXIBLE COUPLING



### 材質 | Material

鋁合金 Aluminum alloy  
緩衝材: 不銹鋼彈片  
Buffer material: SUS disk

### 表面處理 | Surface Treatment

陽極處理 Anodizing standard white

### 特性 | Features

- |  |  |
|--|--|
| <ol style="list-style-type: none"> <li>1. 高剛性</li> <li>2. 扭力大</li> <li>3. 低慣性</li> <li>4. 零背隙</li> <li>5. 適用於工作母機、伺服馬達、<br/>高精密傳動</li> <li>6. 固定方式: 夾緊式</li> </ol> | <ul style="list-style-type: none"> <li>• High rigid</li> <li>• High torque</li> <li>• Low inertia</li> <li>• Zero backlash</li> <li>• Suitable for working machine、<br/>servomotor and high precision<br/>transmission mechanism.</li> <li>• Fixed mode: Clamp type</li> </ul> |
|--|--|

### 型號表示 | Product NO

**SGH-50C- $\phi$ 15x $\phi$ 15**

型號 / Type      孔徑 / Inside dia

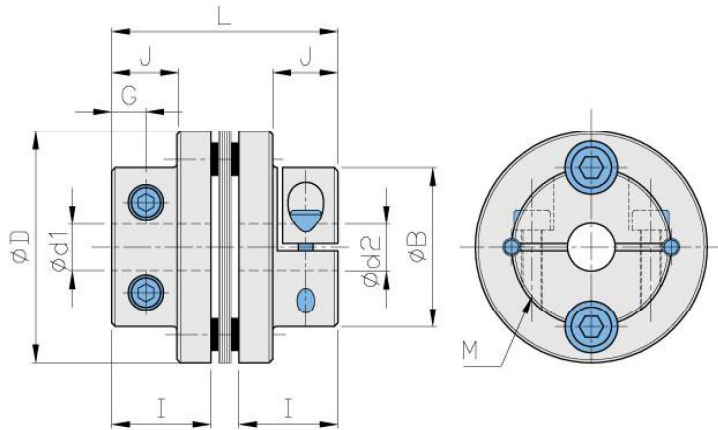

### 尺寸 | Dimension

單位 / Unit:mm

Catalog Number 型號	D	B	J	I	L	G	M	d1xd2 標準孔徑 (H7)		Mass** 重量 (g)
								Min	Max	
SGH-40C	40	28	10.5	15	34.5	4.75	2-M4	8	16	63
SGH-45C	45	33	10.5	15	34.5	4.75	4-M4	10	18	88
SGH-50C	50	40	15	20	46.5	7	4-M5	12	20	120
SGH-57C	57	42	14	20	47	6	4-M5	10	22	175
SGH-65C	65	50	18	24	55	8	4-M6	15	25	200

### 性能 | Specifications

單位 / Unit:mm

Catalog Number 型號	Rated Torque 一般扭力 (N.m)	Max. Torque 最大扭力 (N.m)	Max Rotational Frequency 最高回轉速 (Rpm/min)	Moment* of Inertia 慣性 (Kg · m <sup>2</sup> )	Errors of Shaft End-Play 容許軸向位差 (mm)	Errors of Angularity 容許偏角 (°)
SGH-40C	6	12	10000	9.2x10 <sup>-6</sup>	±0.02	1.0
SGH-45C	9	18	10000	23.2x10 <sup>-6</sup>	±0.02	1.0
SGH-50C	17	34	10000	32.6x10 <sup>-6</sup>	±0.02	1.0
SGH-57C	25	50	10000	51.2x10 <sup>-6</sup>	±0.02	1.0
SGH-65C	55	110	10000	127.4x10 <sup>-6</sup>	±0.02	1.0