

SMT 螺旋型 / 止付螺絲固定式 / 撓性聯軸器

SHAPED SPIRALLY / SET SCREW TYPE / FLEXIBLE COUPLING



材質 | Material

鋁合金 Aluminum alloy

表面處理 | Surface Treatment

陽極處理 Anodizing standard white

特性 | Features

1. 一體成型
2. 零背隙
3. 螺旋式溝槽，可撓性特佳
4. 最適合譯馬器
5. 固定方式：止付螺絲固定式

- One-body shape
- Zero backlash
- Spiral groove, great flexible performance
- Suitable for encoder
- Fixed mode: Set screw type

型號表示 | Product NO

SMT-20- $\phi 6 \times \phi 6$
 型號/Type 孔徑/Inside dia

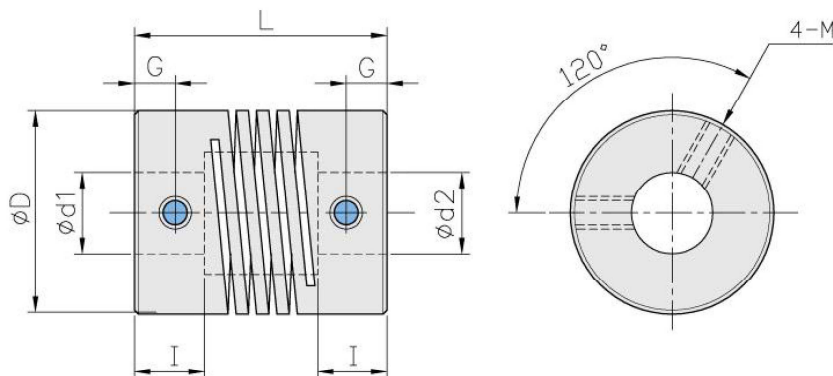

尺寸 | Dimension

單位 / Unit:mm

Catalog Number 型號	D	I	L	G	M	d1xd2 標準孔徑 (H7)		Mass** 重量 (g)
						Min	Max	
SMT-16	16	7.6	23	3.5	M3	4	8	10
SMT-16S	16	4.3	16	2.5	M3	4	8	8
SMT-19	19	7	23	3	M3	5	8	13
SMT-19S	19	5	19	3	M3	5	8	11
SMT-20	20	8.6	26	3	M4	6	10	15
SMT-25	25	10.6	31	4	M4	6	12	31
SMT-25S	25	7.5	25	4	M4	6	12	29

性能 | Specifications

單位 / Unit:mm

Catalog Number 型號	Rated Torque 一般扭力 (N.m)	Max. Torque 最大扭力 (N.m)	Max Rotational Frequency 最高回轉速 (Rpm/min)	Moment* of Inertia 慣性 (Kg · m ²)	Errors of Eccentricity 容許偏心 (mm)	Errors of Angularity 容許偏角 (°)
SMT-16	0.5	1.0	25000	± 0.25	0.25	5
SMT-16S	0.5	1.0	25000	± 0.25	0.25	5
SMT-19	1.0	2.0	25000	± 0.25	0.25	5
SMT-19S	1.0	2.0	25000	± 0.25	0.25	5
SMT-20	1.1	2.2	25000	± 0.25	0.25	5
SMT-25	1.6	3.2	25000	± 0.25	0.25	5
SMT-25S	1.6	3.2	25000	± 0.25	0.25	5