

SWS 開縫型 / 止付螺絲固定式 / 短型撓性聯軸器

SWSS SLITTED / SET SCREW TYPE / SHORTER OF FLEXIBLE COUPLING



材質 | Material

SWS 系列-鋁合金 Aluminum alloy
SWSS 系列-不銹鋼 Stainless steel

表面處理 | Surface Treatment

SWS-陽極處理 Anodizing standard white

特性 | Features

1. 一體成型、小巧
 2. 零背隙
 3. 剛性大
 4. 適合譯碼器、小馬力傳動機構、高精度傳動上
 5. 偏角誤差較佳
 6. 不銹鋼材質扭力較佳
 7. 固定方式: 止付螺絲固定式
- Little and One-body shape
 - Zero backlash
 - High rigid
 - Suitable for encoder、low horsepower transmission bodies and high precision transmission mechanism.
 - High deflection
 - Torque in SUS is better
 - Fixed mode: Set screw type

型號表示 | Product NO

SWS-20- $\phi 6 \times \phi 6$
型號 / Type 孔徑 / Inside dia

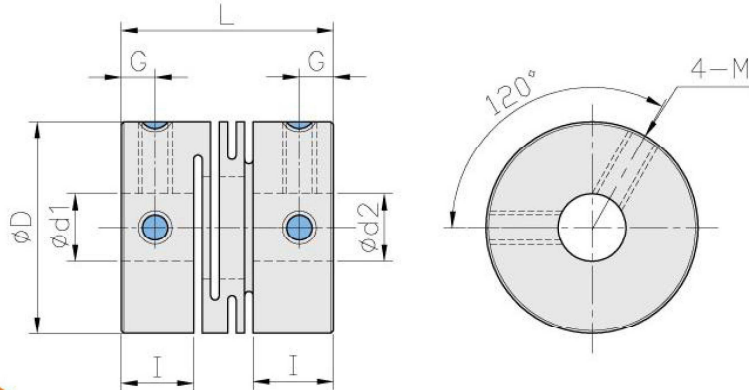

尺寸 | Dimension

單位 / Unit:mm

Catalog Number 型號	D	I	L	G	M	d1xd2 標準孔徑 (H7)		Mass** 重量 (g)
						Min	Max	
SWS-16	16	6.8	18	3	M3	4	6	7.4
SWS-20	20	7.65	20	3	M4	5	10	12
SWS-25	25	9.6	25	4	M4	6	12	24
SWS-32	32	12.6	32	6	M5	6	14	50
SWS-40	40	15.3	40	7.5	M5	10	16	115
SWSS-16	16	6.8	18	3	M3	5	6	18
SWSS-20	20	7.65	20	3	M4	5	10	32
SWSS-25	25	9.6	25	4	M4	6	12	63
SWSS-32	32	12.6	32	6	M5	6	14	130

性能 | Specifications

單位 / Unit:mm

Catalog Number 型號	Rated Torque 一般扭力 (N.m)	Max. Torque 最大扭力 (N.m)	Max Rotational Frequency 最高回轉速 (Rpm/min)	Moment*of Inertia 慣性 (Kg · m ²)	Errors of Angularity 容許偏角 (°)	Errors of Shaft End-Play 容許軸向位差 (mm)
SWS-16	0.3	0.6	24000	2.8x10 ⁻⁷	1	±0.2
SWS-20	0.5	1	19000	7.5x10 ⁻⁷	1	±0.2
SWS-25	1	2	15000	2.3x10 ⁻⁶	1	±0.2
SWS-32	2	4	12000	8.0x10 ⁻⁶	1	±0.2
SWS-40	5	10	9800	3.0x10 ⁻⁵	1	±0.2
SWSS-16	0.5	1	24000	7.2x10 ⁻⁷	1	±0.1
SWSS-20	1	2	19000	2.0x10 ⁻⁶	1	±0.1
SWSS-25	2	4	15000	6.1x10 ⁻⁶	1	±0.2
SWSS-32	3.5	7	12000	2.1x10 ⁻⁵	1	±0.2