

# SWS-C 開縫型/夾緊式/止付螺絲固定式/短型撓性聯軸器

## SWSS-C SLITTED / SET SCREWTYPE / SHORTER of FLEXIBLE COUPLING



SWS-C

SWSS-C

### 材質 | Material

SWS 系列-鋁合金 Aluminum alloy  
SWSS 系列-不銹鋼 Stainless steel

### 表面處理 | Surface Treatment

SWS-C陽極處理 Anodizing standard white

### 特性 | Features

- |   |   |
|---|---|
| <ol style="list-style-type: none"> <li>1. 一體成型、小巧</li> <li>2. 零背隙</li> <li>3. 剛性大</li> <li>4. 適合譯碼器、小馬力傳動機構、高精密傳動上</li> <li>5. 偏角誤差較佳</li> <li>6. 不銹鋼材質扭力較佳</li> <li>7. 不銹鋼材質較適用於無塵室</li> <li>8. 固定方式: 夾緊式</li> </ol> | <ul style="list-style-type: none"> <li>• Little and One-body shape</li> <li>• Zero backlash</li> <li>• High rigid</li> <li>• Suitable for encoder、low horsepower transmission bodies and high precision transmission mechanism.</li> <li>• High deflection</li> <li>• Torque in SUS is better.</li> <li>• SUS is suita</li> <li>• Fixed mode: Clamp type</li> </ul> |
|---|---|

### 型號表示 | Product NO

**SWS-20C- $\phi 6 \times \phi 6$**

型號 / Type      孔徑 / Inside dia

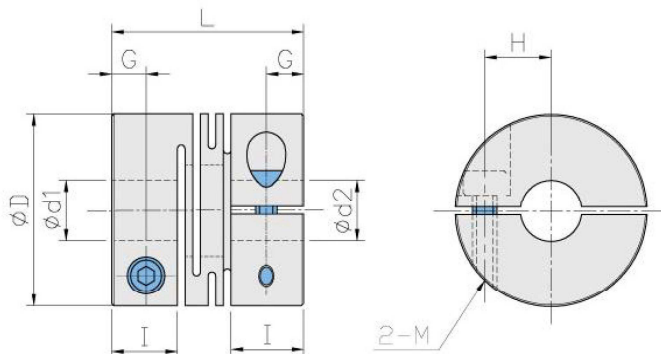

### 尺寸 | Dimension

單位 / Unit:mm

Catalog Number 型號	D	I	L	G	H	M	d1xd2 標準孔徑 (H7)		Mass** 重量 (g)
							Min	Max	
SWS-16C	16	6.8	18	3.4	5	M2.5	4	6	8
SWS-20C	20	7.65	20	3.8	6.5	M3	5	8	13
SWS-25C	25	9	25	4.8	9	M3	6	10	25
SWS-32C	32	12.6	32	6.3	11	M4	6	14	53
SWS-40C	40	15.3	40	7.5	14	M5	10	16	117
SWSS-16C	16	6.8	18	3.4	5	M2.5	5	6	21
SWSS-20C	20	7.65	20	3.8	6.5	M3	5	8	36
SWSS-25C	25	9.6	25	4.8	9	M3	6	10	69
SWSS-32C	32	12.6	32	6.3	11	M4	8	14	150

### 性能 | Specifications

單位 / Unit:mm

Catalog Number 型號	Rated Torque 一般扭力 (N.m)	Max. Torque 最大扭力 (N.m)	Max Rotational Frequency 最高回轉速 (Rpm/min)	Moment*of Inertia 慣性 (Kg · m <sup>2</sup> )	Errors of Angularity 容許偏角 (°)	Errors of Shaft End-Play 容許軸向位差 (mm)
SWS-16C	0.3	0.6	9500	2.9x10 <sup>-7</sup>	1	±0.2
SWS-20C	0.5	1.0	7600	7.5x10 <sup>-7</sup>	1	±0.2
SWS-25C	1.0	2.0	6100	2.3x10 <sup>-6</sup>	1	±0.2
SWS-32C	2.2	4.0	4800	8.1x10 <sup>-6</sup>	1	±0.2
SWS-40C	5.0	10.0	3800	1.9x10 <sup>-5</sup>	1	±0.2
SWSS-16C	0.5	1.0	9500	7.8x10 <sup>-7</sup>	1	±0.2
SWSS-20C	1.0	2.0	7600	2.1x10 <sup>-6</sup>	1	±0.2
SWSS-25C	2.0	4.0	6100	6.3x10 <sup>-6</sup>	1	±0.2
SWSS-32C	3.5	7.0	4800	2.2x10 <sup>-5</sup>	1	±0.2